

DCM2-250C DIAMOND DRILL IN2

40964 - DCM2-250C - 4000384546

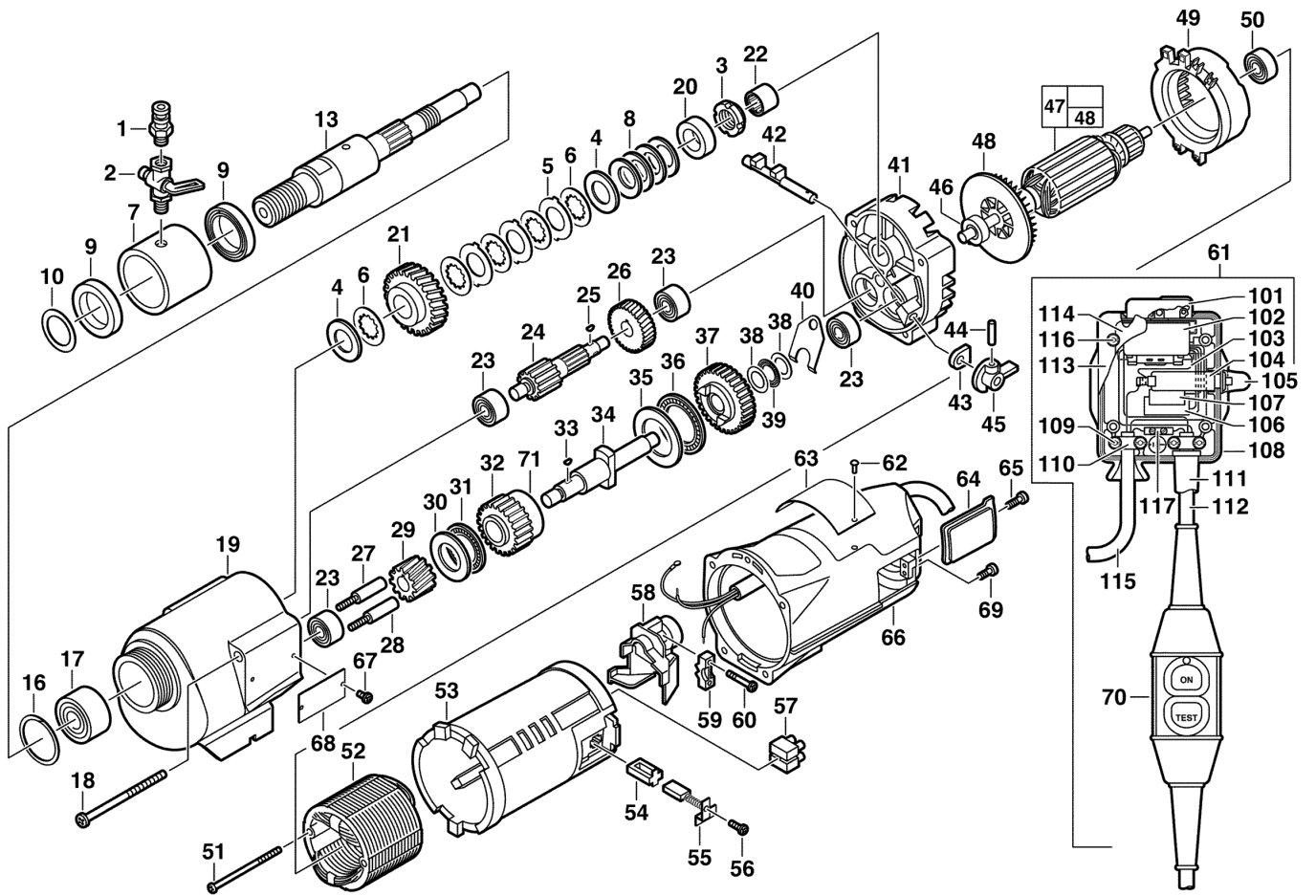



Position	Quantity	Description	Part number	EAN
	1	INSTRUCTION PLATE	5131000000	
0001	1	FITTING	42900210	4058546073282
0002	1	VALVE	45800060	4058546074722
0003	1	NUT	06571050	4058546068547
0004	2	WASHER	45881140	4058546074814
0005	3	DISC	43060160	4058546073312
0006	5	DISC	43060150	4058546073305
0007	1	THREADED SLEEVE	43760051	4058546073619
0008	4	PRESSURE SPRING	40502150	4058546072780
0009	2	SEAL RING	45060635	4058546074326
0010	1	WASHER	45888565	4002395906673
0013	1	SPINDLE	38506020	4058546072636
0016	1	RING	34803800	4058546072407
0017	1	BALL BEARING	02202515	4058546068172
0018	1	SCREW	06829202	4002395894390
0019	1	BODY	28141870	4058546070922
0020	1	SPACER	45361520	4058546074678
0021	1	SPINDLE GEAR	32753420	4058546072025
0022	1	NEEDLE BEARING	02504830	4002395841455
0023	3	BALL BEARING	02041205	4058546068059
0024	1	SHAFT	36663751	4058546072506
0025	1	KEY	06421600	4058546068486
0026	1	GEAR	32401581	4058546071806
0027	2	PRESSURE SPRING	40506300	4002395841400
0028	2	PLUNGER	44700100	4058546074074
0029	1	GEAR BOX	32601041	4058546071912
0030	1	WASHER	45880520	4058546074746
0031	1	THRUST BEARING	02801800	4058546068325
0032	1	GEAR	32100060	4058546071745
0033	1	KEY	06422000	4058546068493
0034	1	CLUTCH SHAFT	36140061	4058546072438
0035	1	WASHER	45880530	4058546074753
0036	1	THRUST BEARING	02805000	4058546068332
0037	1	GEAR BOX	32100051	4058546071738
0038	2	WASHER	45880510	4058546074739
0039	1	THRUST BEARING	02801200	4002395841431
0040	1	YOKE	45980090	4058546074982
0041	1	BEARING END PLATE	14130210	4058546069438
0042	1	SLIDING SWITCH	30150272	4058546071196
0043	2	GASKET	43440580	4058546073428
0044	1	PIN	06650840	4058546068578
0045	1	TRIGGER	25600056	4058546070878
0046	1	BALL BEARING	4931440556	4002395890767
0047	1	ARMATURE ASSEMBLY	16760325	4058546069711
0048	1	FAN	22840790	4058546070342
0049	1	AIR DEFLECTOR RING	42140291	4058546072940
0050	1	BALL BEARING	02041041	4002395841462
0051	1	SCREW	06829152	4058546069131
0052	1	ELECTRIC FIELD	18740120	4058546069766
0053	1	ISOLATION MODULE	23161410	4058546070397

Position	Quantité	Désignation	Référence	EAN
0054	2	BRUSH HOLDER	22200680	4002395841417
0055	2	CARBON BRUSH	22180706	4002395841424
0056	2	SCREW	06828835	4058546069070
0057	1	TERMINAL	22560470	4058546070144
0058	1	CLAMP	22380140	4058546070113
0059	1	CLAMPING PIECE	31170200	4058546071424
0060	2	SCREW	06827326	4058546069018
0061	1	CONTROL DEVICE	23370160	4058546070410
0062	2	RIVET	06721720	4058546068639
0063	1	NAME PLATE	5131000000	
0064	2	BRUSH COVER	22320350	4058546070021
0065	2	SCREW	06825316	4058546068851
0066	1	HOUSING	28506363	4058546071165
0067	2	SCREW	06825266	4058546068837
0068	1	INSTRUCTION PLATE	5131000000	
0069	1	SCREW	06955200	4058546069261
0070	1	CABLE HARNESS	4931472579	4058546328818
0071	1	SPACER	45360225	4058546074623
0101	1	SWITCH COVER	22680200	4058546070298
0102	1	SWITCH	23661430	4058546070526
0103	1	CABLE SET	23949915	4058546070861
0104	1	CABLE HARNESS	22360150	4058546070106
0105	1	SWITCH COVER	22680210	4058546070304
0106	1	CAPACITOR	22330430	4058546070052
0107	1	OVERVOLT. PROT.DEV.	22740053	4002395847747
0108	1	SWITCH COVER	22120200	4058546069780
0109	1	SCREW 8-16X7/8 PAN SL PLS	06827299	4058546069001
0110	2	CLAMPING PIECE	31170155	4058546071400
0111	1	CABLE CLAMP	44760140	4058546074098
0112	1	CABLE	22644075	4058546070267
0113	1	COVER	22680190	4058546070281
0115	1	CONNECTION CABLE	22645050	4002395774029
0116	4	SCREW	06827326	4058546069018
0117	1	CLAMP	5131000000	
0120	1	ALLEN KEY	5131000000	