

# AS-30LAC AC 30L L CLASS VAC CH

4933464775 - AS-30LAC - 4000469290

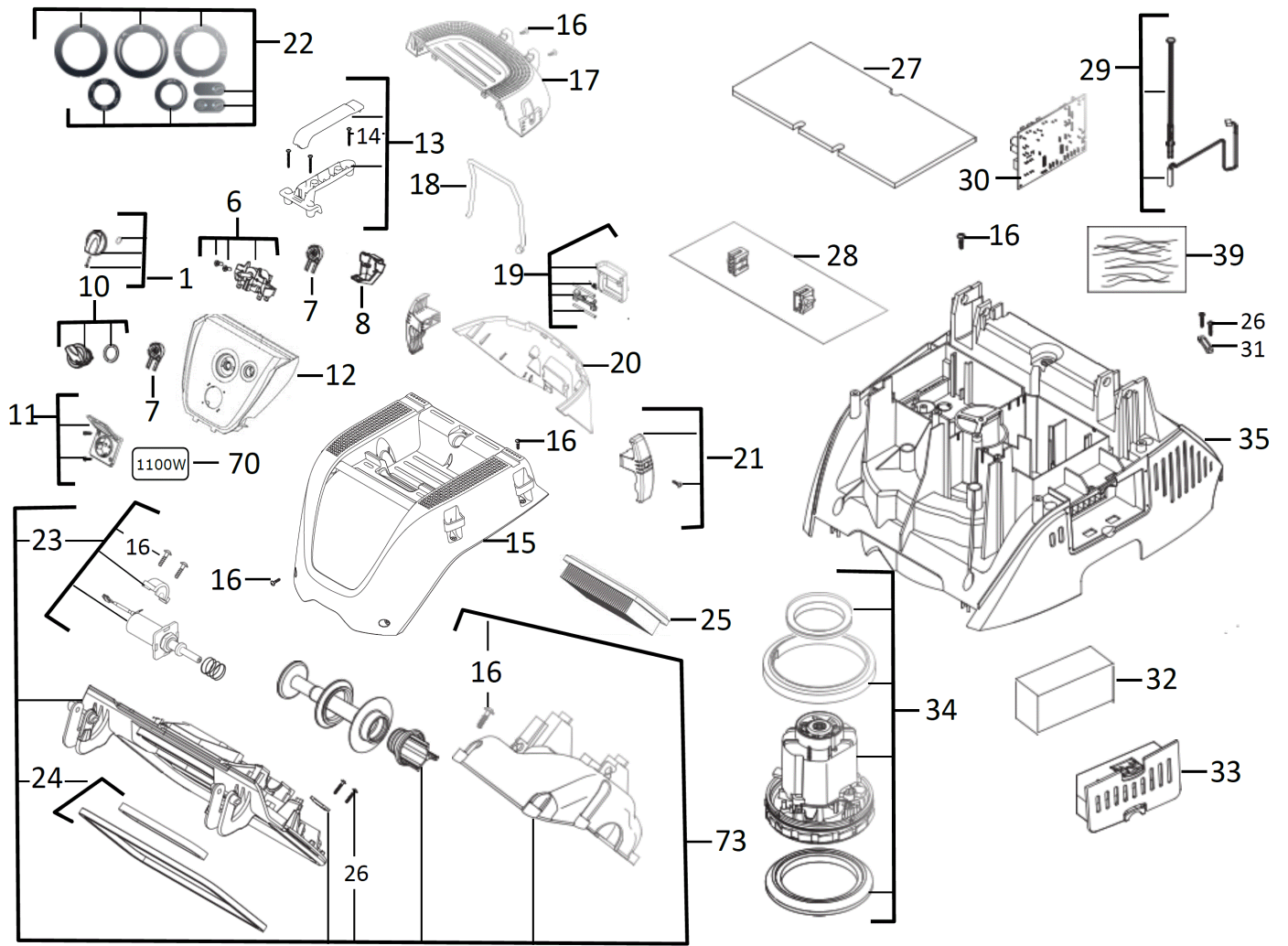

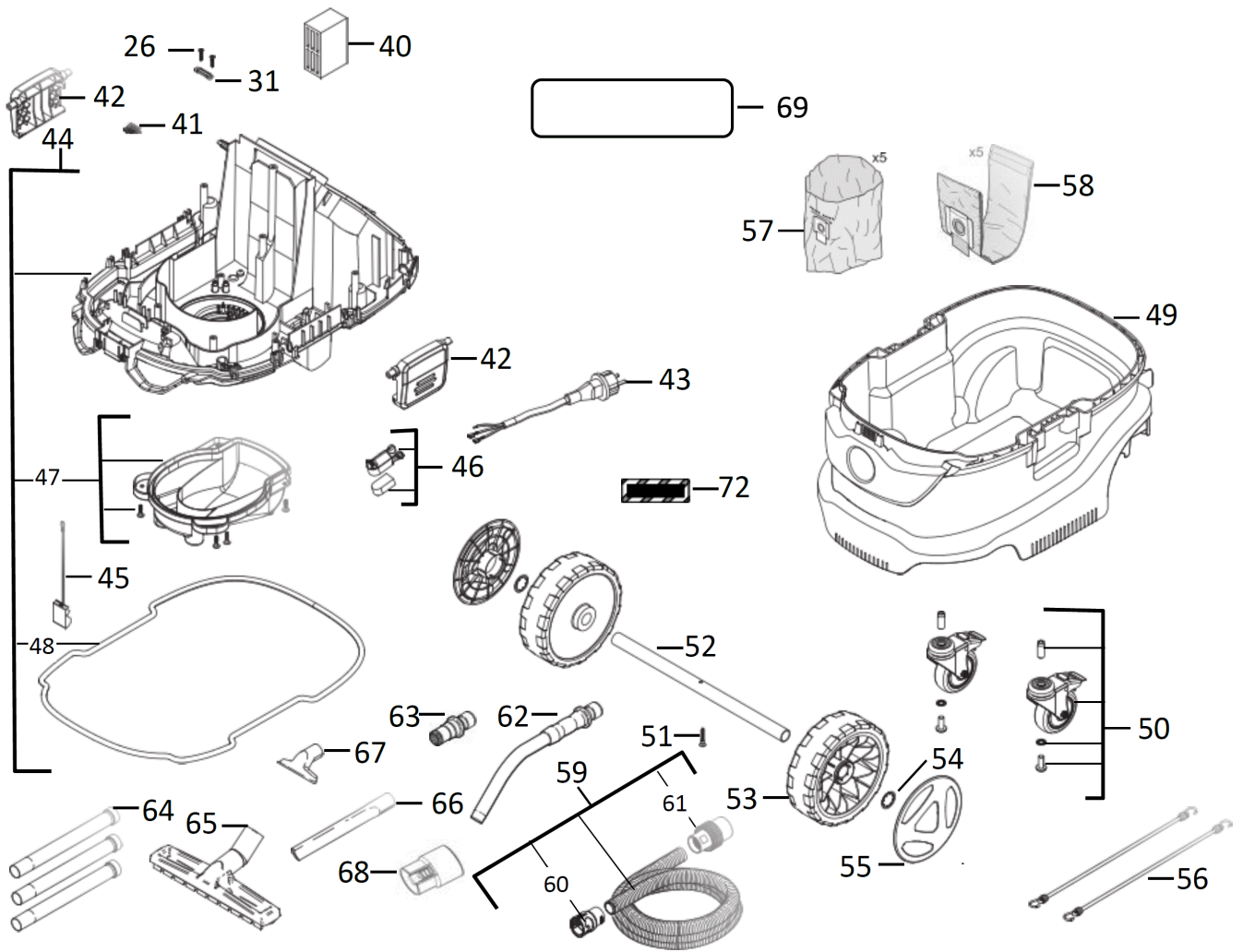



Position	Quantity	Description	Part number	EAN
0001	1	KNOB	4931416119	4002395805389
0006	1	SWITCH KIT	4931461823	4058546040567
0007	2	POTENTIOMETER	4931461824	4058546040574
0008	1	COVER	4931461825	4058546040581
0010	2	KNOB	4931461826	4058546040598
0011	1	WALL SOCKET	4931416261	4002395796465
0012	1	CONTROL PANEL KIT	4931461827	4058546040604
0013	1	HANDLE SET	4931461828	4058546040611
0014	3	SCREW	4931461829	4058546040628
0015	1	HOUSING COVER	4931461830	4058546040635
0016	17	SCREW	4931448663	4002395261819
0017	1	HOUSING COVER	4931461831	4058546040642
0018	1	WAISTBELT	4931461832	4058546040659
0019	1	CLAMP	4931461833	4058546040666
0020	1	HOUSING COVER	4931461834	4058546040673
0021	2	HOOK	4931461835	4058546040680
0022	1	ADHESIVE LABEL	4931461836	4058546040697
0023	1	COIL	4931461837	4058546040703
0024	1	GASKET	4931461838	4058546040710
0025	1	PTFE FLAT FILTER - 1PC	4932459687	4058546028596
0026	4	SCREW	5131000000	
0027	1	FOAM SLUG	4931461839	4058546040727
0028	1	HOLDING DEVICE	4931461840	4058546040734
0029	1	GAUGE	4931461841	4058546040741
0030	1	ELECTRONIC	4931461842	4058546040758
0031	2	CABLE JOINT	4931416316	4002395797790
0032	1	DIFFUSER	4931461843	4058546040765
0033	1	COVER	4931461844	4058546040772
0034	1	MOTOR ASSEMBLY	4931461845	4058546229450
0035	1	HOUSING COVER	4931461846	4058546229467
0039	1	CAPACITOR	4931461847	4058546229474
0040	1	SHOCK ABSORBER	4931461848	4058546229481
0041	1	CONNECTION SET	5131000000	
0042	2	STAPLE	4931461849	4058546229498
0043	1	POWER CORD	4931469346	4058546270957
0044	1	BODY	4931461850	4058546229504
0045	1	CONTACT SPRING	4931461851	4058546229511
0046	1	MAGNET.DISC FASTEN.	4931461852	4058546229528
0047	1	COVER	4931461853	4058546229535
0048	1	GASKET	4931461854	4058546229542
0049	1	TANK	4931461855	4058546229559
0050	1	ROLL	4931461856	4058546229566
0051	1	SCREW	4931461857	4058546229573
0052	1	AXLE	4931416336	4002395797998
0053	2	ROLL	4931461858	4058546229580
0054	2	SLEEVE	4931416339	4002395795185
0055	2	COVER	4931461859	4058546229597
0056	1	WAISTBELT	4931461860	4058546229603
0057	1	DISPOSAL BAGS (30L) - 5PCS	4932459690	4058546028626
0058	1	AS 30/42 FLEECE FILTER BAGS - 5PCS	4932459689	4058546028619

<b>Position</b>	<b>Quantité</b>	<b>Désignation</b>	<b>Référence</b>	<b>EAN</b>
0059	1	SUCTION HOSE	4931461861	4058546229610
0060	1	ADAPTER	4931461862	4058546229627
0061	1	MUFF	4931416458	4002395847167
0062	1	ADAPTER	4931416166	4002395805495
0063	1	MUFF	4931416173	4002395805501
0064	1	SUCTION TUBE (3 pc)	4931461863	4058546229634
0065	1	FLOOR TOOL	4931448691	4002395256471
0066	1	NOZZLE	4931416284	4002395797097
0067	1	NOZZLE	4931416283	4002395797080
0068	1	CONNECTOR	4931447294	4002395251490
0069	1	SERVICE RATING LABEL AS-30LAC (CH)	4931469347	4058546270841
0070	1	STICKER MAX 1100W	4931410489	4058546270681
0072	1	ADHESIVE LABEL	4931461866	4058546229665
0073	1	FRAME CAP	4931461867	4058546229672