

M18FMT-502X FUEL M18 MULTITOOL IN2

4933478492 - M18FMT-502X IN2 - 4000477865

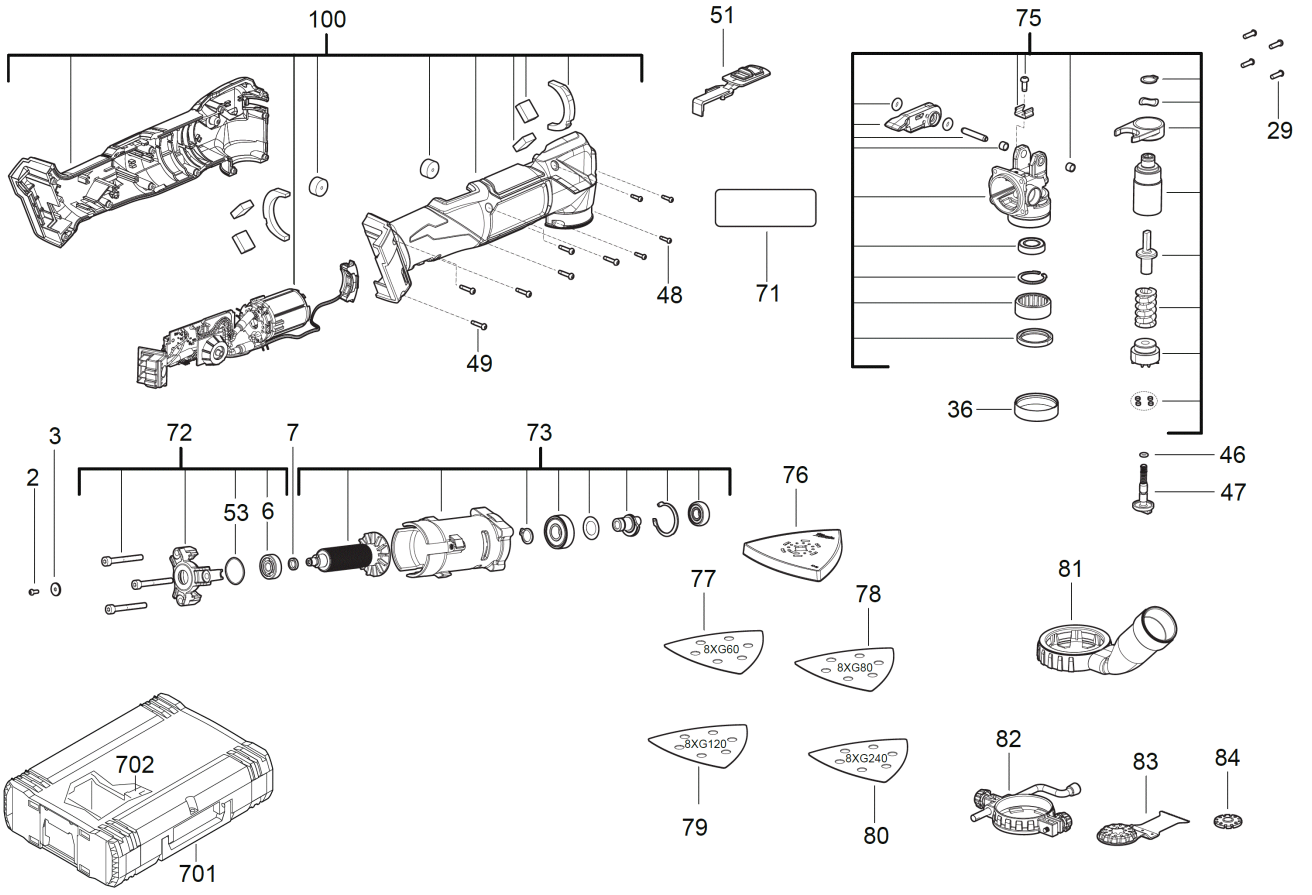



| Position | Quantity | Description | Part number | EAN |
|----------|----------|----------------------------------|-------------|---------------|
| 0002 | 1 | SCREW | 4931465506 | 4058546236069 |
| 0003 | 1 | WASHER | 4931473916 | 4058546364847 |
| 0006 | 1 | BALL BEARING | 4931473917 | 4058546364854 |
| 0007 | 1 | BUSH | 4931473918 | 4058546364861 |
| 0029 | 4 | SCREW | 4931465883 | 4058546239831 |
| 0036 | 1 | RUBBER SLEEVE | 4931473919 | 4058546364878 |
| 0046 | 1 | O-RING | 4931473392 | 4058546352684 |
| 0047 | 1 | FASTENING BOLT | 4931473393 | 4058546352691 |
| 0048 | 4 | SCREW | 4931447534 | 4002395882823 |
| 0049 | 6 | SCREW | 660570005 | 4002395827329 |
| 0051 | 1 | SLIDE | 4931473920 | 4058546364885 |
| 0053 | 1 | O-RING | 4931473921 | 4058546364892 |
| 0071 | 1 | RATING PLATE | 4931473923 | 4058546364915 |
| 0072 | 1 | MOTOR PLATE | 4931473924 | 4058546364922 |
| 0073 | 1 | MOTOR ASSEMBLY | 4931473925 | 4058546364939 |
| 0075 | 1 | GEAR CASE | 4931473927 | 4058546364953 |
| 0076 | 1 | GRINDING DISK | 4931447574 | 4002395882960 |
| 0081 | 1 | DUST EXTR.CONNECTOR | 4931473396 | 4058546352721 |
| 0082 | 1 | DEPTH GAUGE | 4931473397 | 4058546352738 |
| 0083 | 1 | BLADE | 4931473395 | 4058546352714 |
| 0084 | 1 | ADAPTER DISC | 4931473394 | 4058546352707 |
| 0100 | 1 | SET POWERPACK | 4931483512 | 4058546392222 |
| 0702 | 1 | INSERT | 4931473928 | 4058546364960 |
| 0077 | 1 | Sand Paper D HL 93x93/6 G60-8pc | 48902060 | 45242349166 |
| 0078 | 1 | Sand Paper D HL 93x93/6 G80-8pc | 48902080 | 45242349173 |
| 0079 | 1 | Sand Paper D HL 93x93/6 G120-8pc | 48902120 | 45242349135 |
| 0080 | 1 | Sand Paper D HL 93x93/6 G240-8pc | 48902240 | 45242366064 |
| 0701 | 1 | HD Box 1 - 1pc | 4932453385 | 4002395146376 |