

# Operator's manual



## TruTool TKF 1500 (3A1), (3B1)

Beveler

---

TRUMPF Werkzeugmaschinen GmbH + Co. KG, Technische Redaktion  
Johann-Maus-Straße 2, D-71254 Ditzingen  
Fon: +49 7156 303 - 0  
Internet: <http://www.trumpf.com>  
E-Mail: [docu.th@de.trumpf.com](mailto:docu.th@de.trumpf.com)





# Table of contents

<b>1</b>	<b>Safety</b>	<b>3</b>
1.1	General safety information	3
1.2	Specific safety information for bevelers	3
<b>2</b>	<b>Description</b>	<b>5</b>
2.1	Intended use	5
2.2	Technical data	6
2.3	Icons	8
2.4	Noise and vibration information	8
<b>3</b>	<b>Setting work</b>	<b>10</b>
3.1	Adjusting the ram length	10
3.2	Adjusting the angle of bevel	12
3.3	Setting material thickness	13
3.4	Selecting cutting tool	13
3.5	Adjusting height of the cutting tool	15
3.6	Select gear	16
3.7	Accessories included	17
	Securing the chip box	17
	Handle base	18
	Tube-shaped handle	18
	Roller holder	19
3.8	Options	20
	Roller holder for pipe and tube processing	20
	Special tool for pipe and tube processing	21
	Conversion kits for large material thicknesses	23
	Suspension bracket	25
	Workstation	26
<b>4</b>	<b>Operation</b>	<b>28</b>
4.1	Working with TruTool TKF 1500 (3A1), (3B1)	28
<b>5</b>	<b>Maintenance</b>	<b>30</b>
5.1	Regrinding cutting tool	30
5.2	Changing the cutting tool	31
5.3	Change the sliding sleeve	32

---

<b>6</b>	<b>Accessories and consumables</b>	<b>34</b>
6.1	Ordering consumables	35
<b>7</b>	<b>Appendix: Declaration of conformity, guarantee, replacement parts lists</b>	<b>36</b>

# 1. Safety

## 1.1 General safety information

### WARNING

**Read all the safety information and instructions.**

- Failure to comply with the safety information and instructions can cause electric shock, burns and/or serious injury.
- Retain all the safety information and instructions for future use.

## 1.2 Specific safety information for bevelers

### DANGER

**Electrical voltage! Risk of fatal injury due to electric shock!**

- Always keep the power cable behind the device and do not pull it over sharp edges.
- Do not perform any work that may cause the machine to come into contact with hidden power lines or its own cable. Contact with a live conductor can cause metallic machine parts to become live and can lead to an electric shock.

### WARNING

**Risk of injury from hot and sharp chips!**

**Chips exit the chip ejector at high speed.**

- Use the chip box.

### WARNING

**Risk of injury from falling machinery**

**The entire weight of the machine must be taken up after machining the workpiece.**

- Use the suspension bracket with balancer.
- Use the suspension cable.

### CAUTION

**Damage to property due to improper handling.**

**Collisions could result from setting the machine incorrectly.**

- Rotate the eccentric shaft one full turn in a clockwise direction using the Allen key provided. If no more collisions occur, remove the Allen key and put the machine into operation in accordance with regulations.

 **WARNING****Risk of injury to hands.**

- Do not reach into the processing line with your hands.
- Use both hands to hold the machine.

## 2. Description

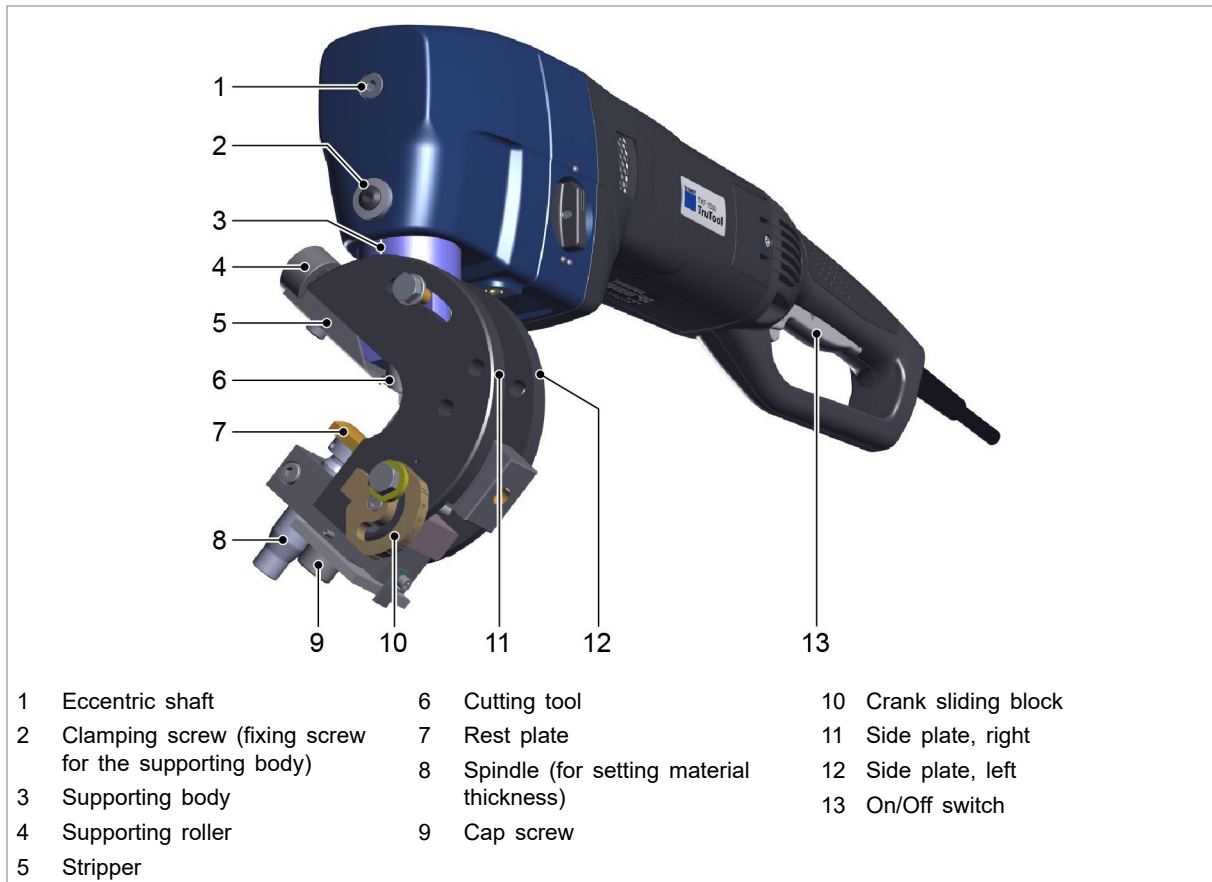

TruTool TKF 1500 beveler (3A1), (3B1)

Fig. 84792

### 2.1 Intended use

The TRUMPF TruTool TKF 1500 beveler (3A1), (3B1) is an electrical powered hand-held device designed for the following applications:

- Preparation of all K-, V-, X- and Y-shaped welding grooves usual for gas and electrical fusion welding with various continuously adjustable angles of bevel and continuously adjustable lengths of bevels.
- Forming of uniform, oxide-free, bright metallic welding bevel edges in steel and aluminum.
- Machining of chromium steel and similar high-tensile materials (recommendation: machine in 2-gear version).
- Beveling of straight and curved edges, provided the minimum radius of the inner curve is 55 mm.
- Beveling of edges on level and crooked workpieces, in particular tubes with an inside diameter of at least 100 mm.

- Beveling of edges in both directions, with the beveling process being able to be started and finished at any point of the sheet edge.
- Beveling of edges on large, bulky workpieces, for which the beveling machine is guided as a hand-held device.
- Beveling of edges in normal position (carrier below the machine) and in "upside-down position" (carrier above the machine), which is of advantage in particular when beveling X and K welding joints.

The TRUMPF TruTool TKF 1500 beveler (3B1) also offers 2-gear changing for modifying the working speed when machining high-tensile materials.



## 2.2 Technical data

TruTool TKF 1500 (3A1)

	Other countries			USA
	Values			
<b>Voltage</b>	230 V 220 V (China)	120 V	110 V	120 V
<b>Frequency</b>	50/60 Hz			50/60 Hz
<b>Max. length of bevel "ls" continuously adjustable:</b>				
<b>Mild steel and aluminum up to 400 N/mm<sup>2</sup></b>	15 mm			0.59 in
<b>Mild steel up to 600 N/mm<sup>2</sup></b>	9 mm			0.354 in
<b>Mild steel up to 800 N/mm<sup>2</sup></b>	6 mm			0.236 in
<b>Working Speed</b>	2 m/min			6.55 ft/min
<b>Nominal power consumption</b>	2600 W	2000 W	2000 W	-
<b>Rated current:</b>	-			16 A
<b>Stroke rate with nominal load</b>	370/min	340/min	340/min	340/min
<b>Weight</b>	16.5 kg			36.7 lbs
<b>Material thicknesses:</b>				
<b>Min.</b>	6 mm			0.236 in
<b>Max.</b>	40 mm			1.57 in
<b>Special</b>	40-80 mm 80-120 mm 120-160 mm			1.57-3.14 in 3.14-4.71 in 4.71-6.28 in
<b>Angle of bevel "β" continuously adjustable</b>	20°-45°			20°-45°
<b>With special stripper</b>	20°-55°			20°-55°





TruTool TKF 1500 (3A1)

	Other countries	USA
Values		
Smallest radius with inner cutouts	55 mm	2.17 in
Safety class	II / 	II / 

Tab. 1

TruTool TKF 1500 (3B1)



	Other countries	USA
Values		
Voltage	230 V 220 V (China)	120 V 110 V 120 V
Frequency	50/60 Hz	50/60 Hz
<b>Max. length of bevel "ls" continuously adjustable:</b>		
Mild steel and aluminum up to 400 N/mm <sup>2</sup>	15 mm (1st + 2nd gear)	0.59 in
Mild steel up to 600 N/mm <sup>2</sup>	11 mm (1st gear) 9 mm (2nd gear)	0.433 in 0.354 in
Mild steel up to 800 N/mm <sup>2</sup>	9 mm (1st gear) 6 mm (2nd gear)	0.354 in 0.236 in
Working Speed	1.25 m/min (1st gear) 2 m/min (2nd gear)	4.1 ft/min (1st gear) 6.55 ft/min (2nd gear)
Nominal power consumption	2600 W 2000 W	2000 W -
Rated current:	-	16 A
Stroke rate with nominal load	230/min (1st gear) 370/min (2nd gear)	170/min (1st gear) 340/min (2nd gear)
Weight with guide handle	19.5 kg	43.3 lbs
<b>Material thicknesses:</b>		
Min.	6 mm	0.236 in
Max.	40 mm	1.57 in
Special	40-80 mm 80-120 mm 120-160 mm	1.57-3.14 in 3.14-4.71 in 4.71-6.28 in
Angle of bevel "ß" continuously adjustable	20°-45°	20°-45°
With special stripper	20°-55°	20°-55°
Smallest radius with inner cutouts	55 mm	2.17 in
Safety class	II / 	II / 

Tab. 2

## 2.3 Icons

### Note

The following symbols are important for reading and understanding the operator's manual. The correct interpretation of the symbols will help you operate the machine better and safer.

Icon	Name	Description
	Read operator's manual	Read the operator's manual and safety information in their entirety before starting up the machine. Closely follow the instructions given.
	Safety class II	Indicates a doubly insulated tool.
	Alternating current	Type or property of current
V	Volt	Voltage
A	Ampere	Current, current input
Hz	Hertz	Frequency (oscillations per second)
W	Watt	Power, power input
mm	Millimeters	Dimensions e.g.: material thickness, chamfer length
in	Inch	Dimensions e.g.: material thickness, chamfer length
$n_o$	Idle speed	Revolution speed without load
.../min	Revolutions/strokes per minute	Revolution speed, stroke rate per minute

Tab. 3

## 2.4 Noise and vibration information

### WARNING

#### Noise emission value may be exceeded.

- Wear hearing protection.

### WARNING

#### The vibration emission value can be exceeded!

- Select the right tools and exchange them in time in the event of wear.
- Have maintenance carried out by trained specialized technicians.
- Define additional safety measures for protecting the operator from the effect of vibrations (e. g. keep hands warm, organization of working procedures, machining at normal feed force).
- Depending on the operating conditions and state of the electric tool, the actual load might be higher or lower than the specified measured value.

## Notes

- The specified vibration emission value was measured in accordance with a standardized testing procedure and can be used to compare one electric tool with another.
- The specified vibration emission value can also be applied for a provisional estimate of the vibration load.
- Times during which either the machine is switched off or running but not actually in use can considerably reduce the vibration load during the entire working period.

Designation of measured value	Unit	Value according to EN 60745
Vibration emission value $a_h$ (vector sum of three directions)	$m/s^2$	12.1
Uncertainty K for vibration emission value	$m/s^2$	2.5
A-class acoustic pressure level $L_{pA}$ typically	dB (A)	87
A-class acoustic power level $L_{WA}$ typically	dB (A)	98
Uncertainty K for noise emission value	dB	1.5

Tab. 4

### 3. Setting work

#### 3.1 Adjusting the ram length

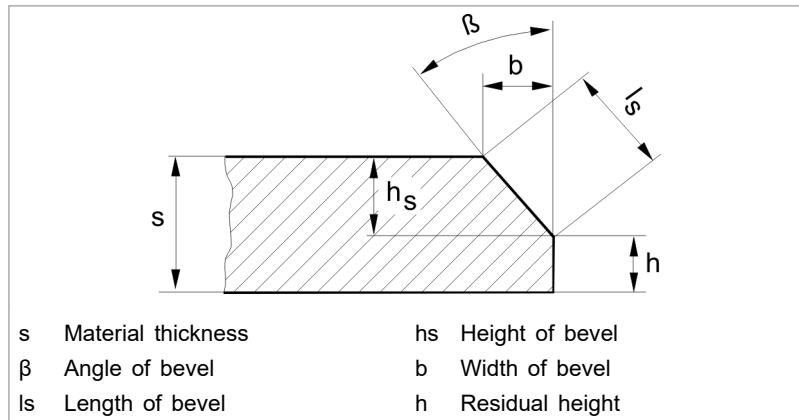

Length of bevel and angle of bevel

Fig. 9664

W	8	7	6	5	4	3	2	1	0	mm
β 55°	14.5	13.3	12.1	10.8	<b>9.7</b>	<b>8.4</b>	<b>7.2</b>	<b>6.0</b>	<b>4.8</b>	ls
	11.9	10.9	9.9	8.9	<b>7.9</b>	<b>6.9</b>	<b>5.9</b>	<b>4.9</b>	<b>3.9</b>	b
	8.3	7.7	7.0	6.2	<b>5.6</b>	<b>4.8</b>	<b>4.2</b>	<b>3.5</b>	<b>2.8</b>	hs
β 45°	15	13.6	12.12	10.8	<b>9.4</b>	<b>8</b>	<b>6.5</b>	<b>5.1</b>	<b>3.7</b>	ls
	10.6	9.6	8.6	7.6	<b>6.6</b>	<b>5.6</b>	<b>4.6</b>	<b>3.6</b>	<b>2.6</b>	b
	10.6	9.6	8.6	7.6	<b>6.6</b>	<b>5.6</b>	<b>4.6</b>	<b>3.6</b>	<b>2.6</b>	hs
β 37.5°	15.5	13.8	12.2	10.5	<b>8.9</b>	<b>7.3</b>	<b>5.6</b>	<b>4</b>	<b>2.4</b>	ls
	9.4	8.4	7.4	6.4	<b>5.4</b>	<b>4.4</b>	<b>3.4</b>	<b>2.4</b>	<b>1.4</b>	b
	12.3	11	9.6	8.3	<b>7</b>	<b>5.8</b>	<b>4.4</b>	<b>3.1</b>	<b>1.9</b>	hs
β 30°	-	15	13	11	<b>9</b>	<b>7</b>	<b>5</b>	<b>3</b>	<b>1</b>	ls
	-	7.5	6.5	5.5	<b>4.5</b>	<b>3.5</b>	<b>2.5</b>	<b>1.5</b>	<b>0.5</b>	b
	-	13	11.2	9.5	<b>7.8</b>	<b>6</b>	<b>4.3</b>	<b>2.6</b>	<b>0.8</b>	hs
β 20°	-	-	15	<b>12.2</b>	<b>9.2</b>	<b>6.2</b>	<b>3.3</b>	-	-	ls
	-	-	5.1	<b>4.2</b>	<b>3.1</b>	<b>2.1</b>	<b>1.1</b>	-	-	b
	-	-	14	<b>11.4</b>	<b>8.6</b>	<b>5.8</b>	<b>3.1</b>	-	-	hs

β Angle of bevel

W Scale value which must be adjusted on the crank sliding block

Tab. 5

For angles of bevel > 45°, machine using special stripper.

Example for working with the table:

β desired	30°
ls	13 mm
W (from the table)	6

Tab. 6

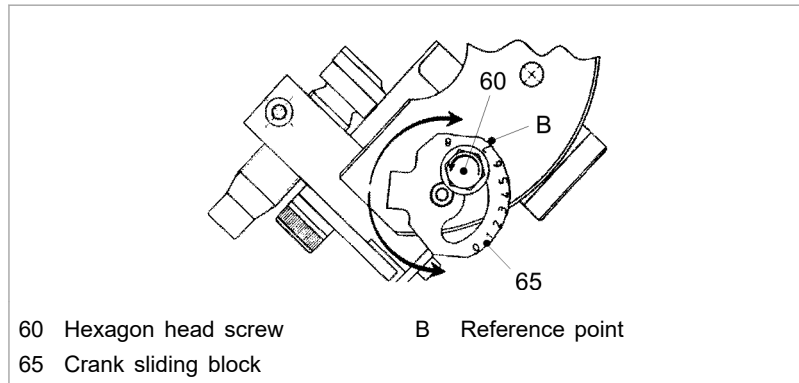

Fig. 10063

1. Undo the hex. screw (60).

**Note**

Observe angle of bevel  $\beta$ .

2. Consult the table to find the desired length of bevel/ram length  $l_s$  and the associated scale value  $W$  (see "Tab. 5", pg. 10).
3. Rotate the crank sliding block (65) until the scale value  $W$  on the crank sliding block lines up with the reference point B.
4. Tighten the hex. screw (60).

## 3.2 Adjusting the angle of bevel

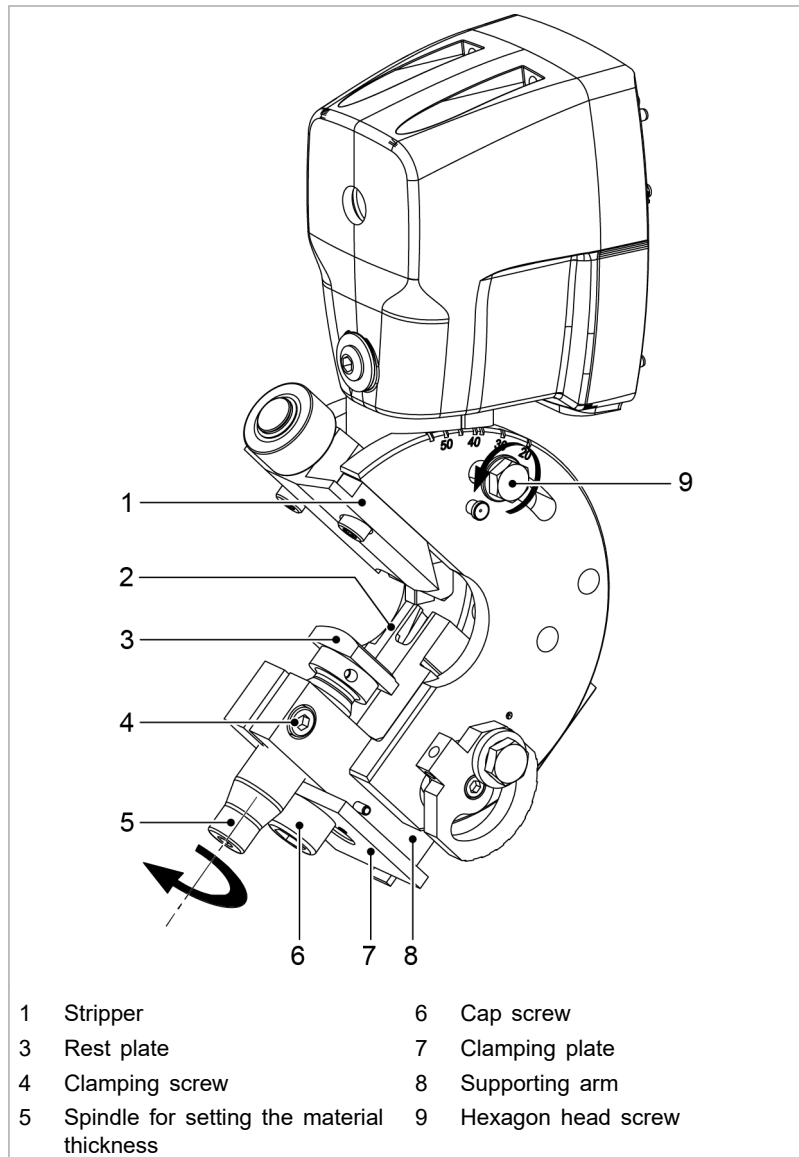

Fig. 84793

### Notes

- With stripper (1), the angle of bevel "β" is continuously adjustable between 20° and 45°.
  - With stripper 55° (order number 0032119), the angle of bevel "β" is adjustable between 20° and 55°. Stripper (1) must be exchanged for this.
1. Undo the screws (9) (on both sides).
  2. Set the desired angle in accordance with the scale.
  3. Retighten the screws (9).

### 3.3 Setting material thickness

1. Position the machine on the sheet (working position).
2. Undo the clamping screw (4).
3. Adjust the rest plate (3) to match the material thickness using the spindle (5). Allow for 0.5 to 1 mm of play when doing so.
4. Lock the spindle (5) into place with the clamping screw (4).

### 3.4 Selecting cutting tool

Cutting tool	Default	High-tensile	Aluminum	High-tensile 5575	Heavy-duty cutting tool
Order number	0088503	0089335	0005014	0005575	0110399
Usage	General mild steel of up to 500 N/mm <sup>2</sup>	Higher-tensile mild steel of up to 650 N/mm <sup>2</sup> chromium steel	Aluminum alloys	High-tensile materials of up to 800 N/mm <sup>2</sup> chromium steel	High-tensile materials
	<p>A = direction of processing E = distinguishing feature</p>				

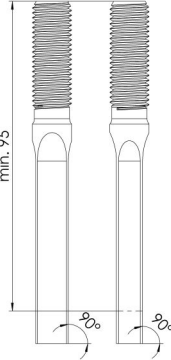
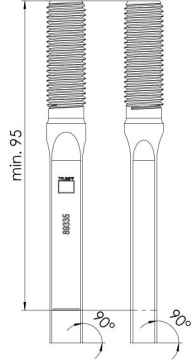
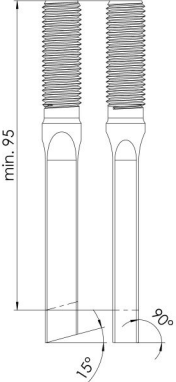
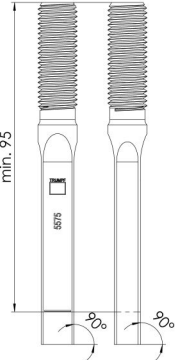
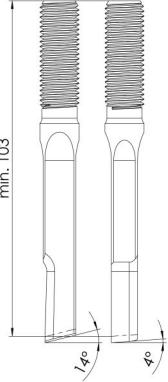
Cutting tool	Default	High-tensile	Aluminum	High-tensile 5575	Heavy-duty cutting tool
<b>Regrinding diagram</b>					
<b>Regrinding reserve</b>	10 mm	10 mm	10 mm	10 mm	2 mm

Cutting tools for TruTool TKF 1500 beveler

Tab. 7

**Note**

Optimum utilization of the high-performance cutting tool is ensured only with the machine in the 2-gear version.



### 3.5 Adjusting height of the cutting tool

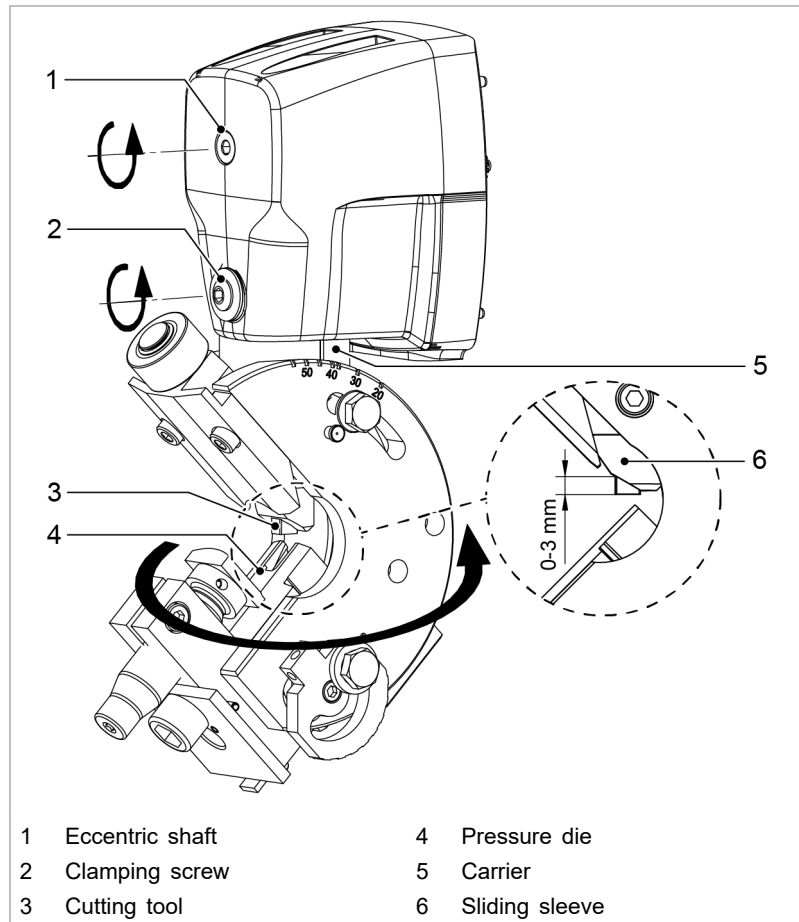

Fig. 84871

Adjust the height of the cutting tool in such a way that it protrudes approximately 1 mm (min. 0, max. 3 mm) out of the sliding sleeve (6).

1. Rotate the eccentric shaft (1) until the cutting tool (3) has achieved its highest point (UDP = upper dead point).
2. Undo the clamping screw (2).
3. Rotate the carrier (5) by 360° as often as needed until the cutting tools protrudes 0-3 mm out of the sliding sleeve (6).
4. One rotation (360°) corresponds to a height adjustment of 1.75 mm.
5. Retighten the clamping screw (2).

### 3.6 Select gear

#### Note

Depending on the material thickness, strength and type of work-piece, a different gear must be selected for machining. Instead of in 2nd gear, 1st gear can always be worked with, but never vice versa.

#### CAUTION

**Damage to property due to turning the gear switch during operation.**

**Damage to the gearbox can be a consequence.**

- Use the gear switch only when the motor is running down or at rest.

#### CAUTION

**Damage to property due to too high a stroke rate**

**Damage to the motor due to an overload can be a consequence.**

- Observe the specifications in the technical data .

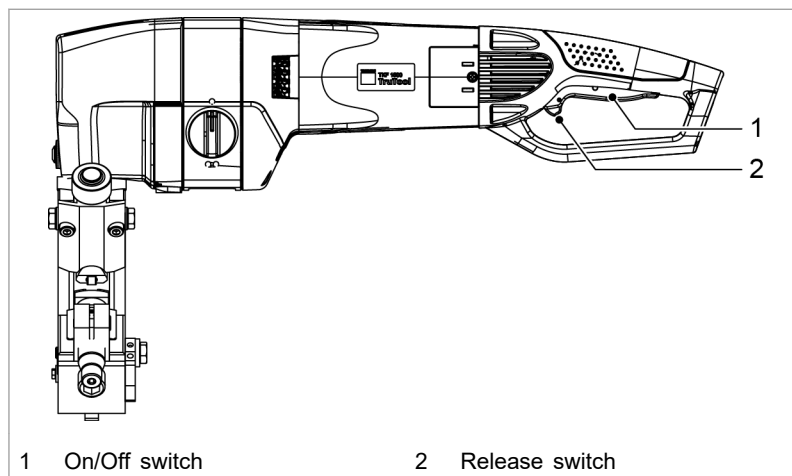

Fig. 84872

1. Put the machine into a stable position.
2. Switch on the machine briefly:
  - Press the release switch (2) forward and hold it.
  - Press the On/Off switch (1).
3. While the motor is running down, turn the gear switch to the desired position.

### 3.7 Accessories included

#### Securing the chip box

Chips that fall away during machining are collected in the chip box.

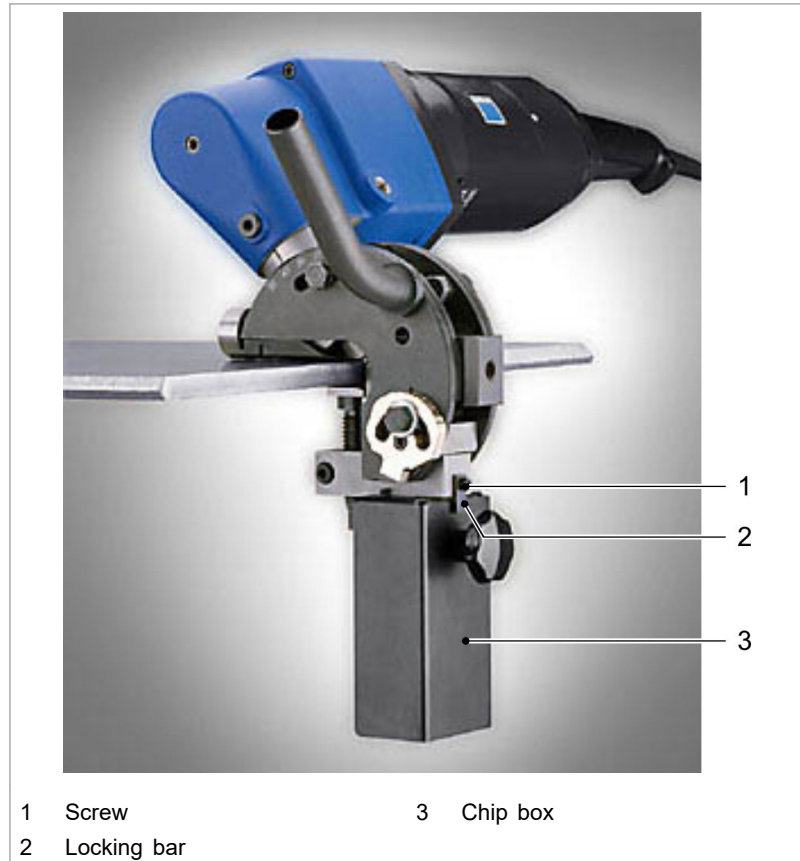

Fig. 54642

1. Push the chip box (3) onto the clamping plate.
2. Loosen screw (1).
3. Turn the locking bar (2) downward.
4. Retighten the screw (1).

The chip box is secured against dropping out.

## Handle base

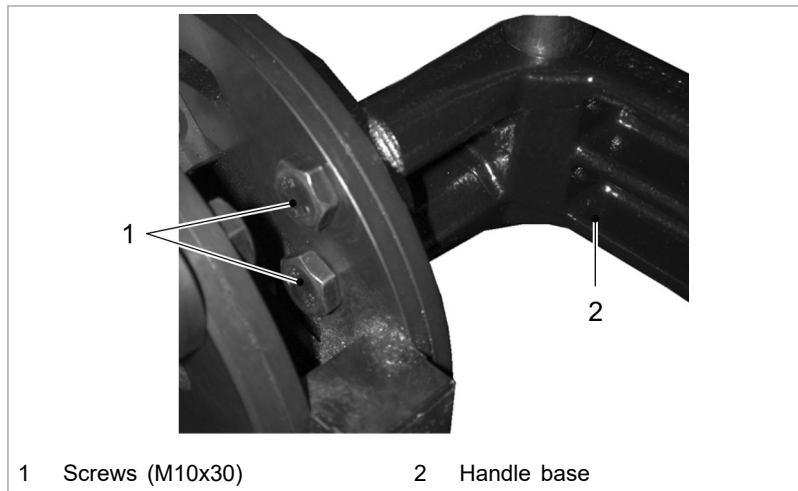

Fig. 42381

- Tighten screws (1).

## Tube-shaped handle

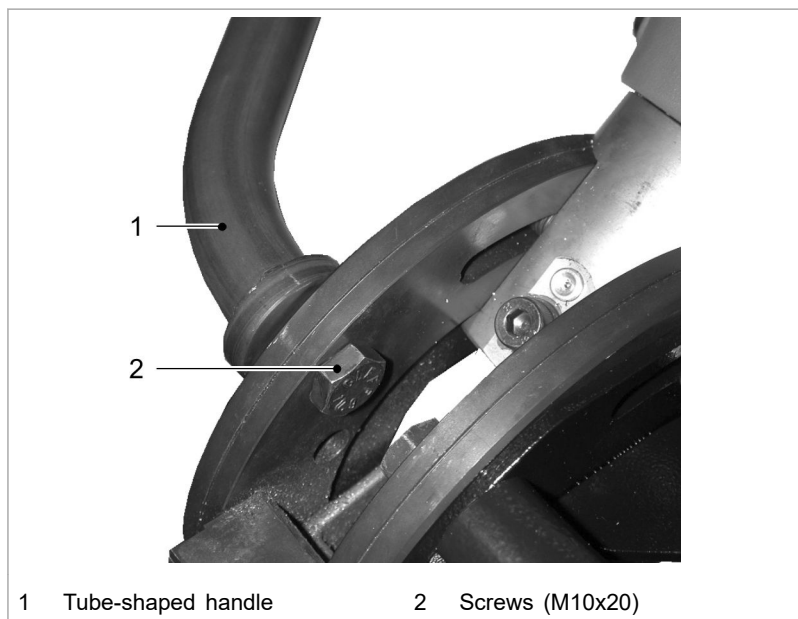

Fig. 41795

### Note

Do not use washers.

- Tighten the tube-shaped handle with a screw (2).

## Roller holder

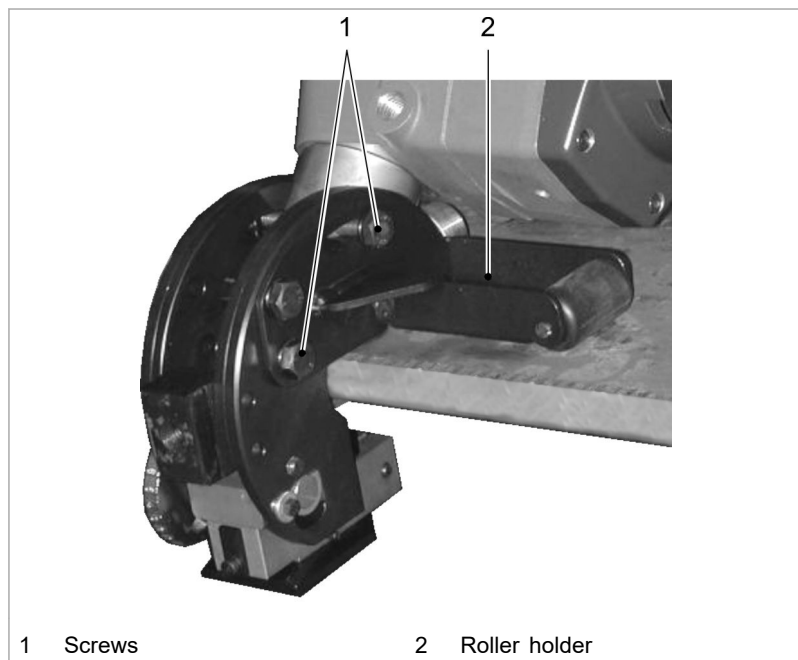

Roller holder on the right-hand side

Fig. 41794

The roller holder on the right-hand side is delivered with the machine as standard. A roller holder for the left-hand side can be ordered separately.

### Roller holder without handle base

1. When the roller holder is to be installed without a handle base, the supplied screws, washers, and nuts will also be required.

### Roller holder with handle base

#### Note

Do not use washers.

2. If the roller holder is also to be installed, it must be clamped between handle base and tool.

## 3.8 Options

### Roller holder for pipe and tube processing

The roller holder below can be used to bevel tubes with an outside diameter of up to 200 mm. The minimum tube inside diameter must be 100 mm.

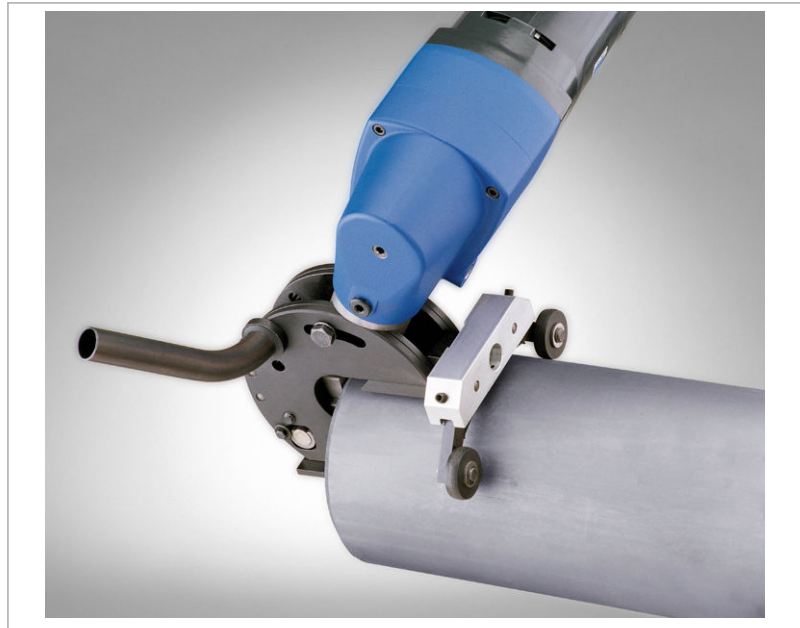

For roller holder for tubes with an outside diameter of up to 200 mm

Fig. 54643

## Installing the roller holder

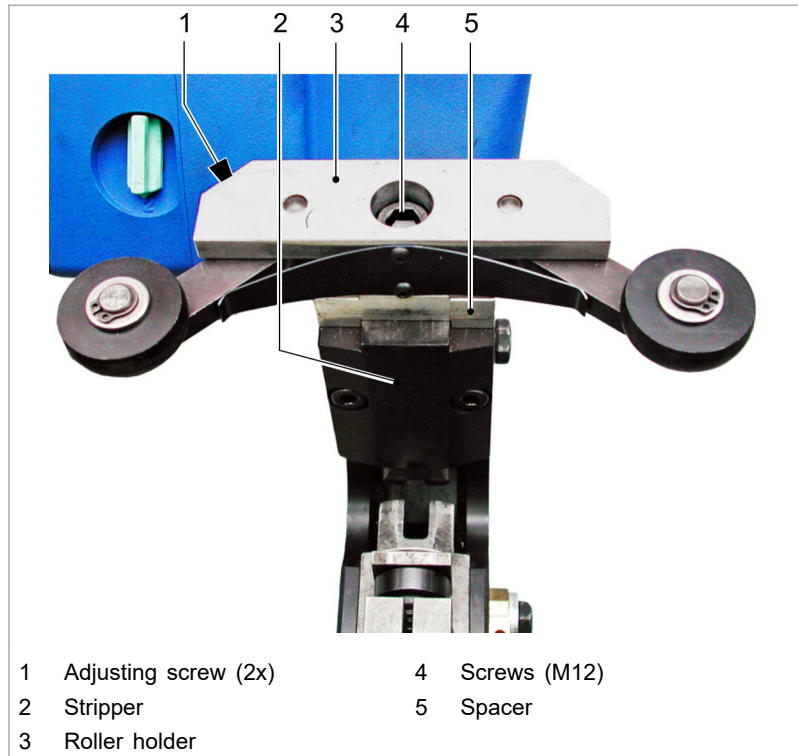
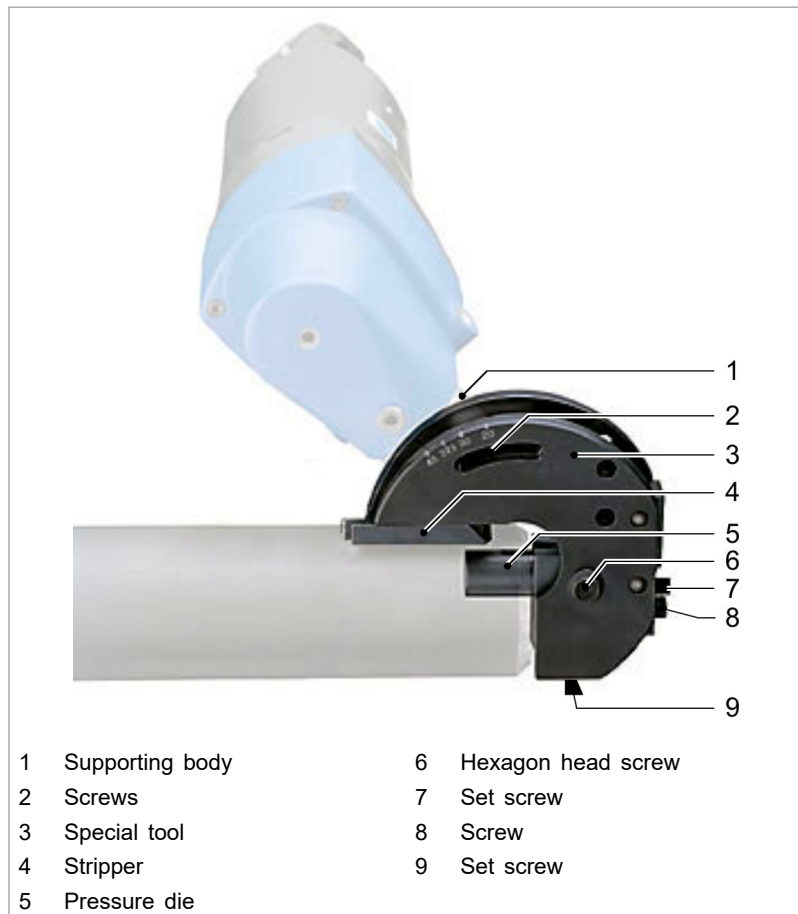

Fig. 54706

1. Undo and remove both of the screws on the stripper (2) using the screwdriver provided.
2. Screw on the special stripper for the pipe and tube processing (order number 0023242).
3. Place the spacer (5) and roller holder (3) on top of each other and fasten them to the machine using the screw (4).
4. Set the material thickness on a level sheet using the spindle.
5. Position the machine on the tube.
6. Use the adjusting screw (1) to align both rollers to the radius of the tube.

## Special tool for pipe and tube processing

The special tool below (order number 0027798) can be used for tube processing for beveling tubes with an inside diameter of 30-120 mm. The wall thickness of the tubes must not exceed 11 mm for this process.



For roller holder for tubes with an inside diameter of 30-120 mm

Fig. 54265

### Removing the guide bracket

1. Undo and remove both of the screws on the stripper using the screwdriver provided.
2. Undo the screws (2) using the open-end wrench provided.
3. Completely extend the guide bracket on the supporting body (1) and remove it from the machine.

### Installing the special tool

4. Loosen the hexagon head screw (6) on the special tool (3), but do not unscrew it completely.
5. Undo the screw (8) on the lever.
6. Remove the pressure die (5) from the special tool.
7. Unscrew both screws from the special tool (3) and remove the stripper (4).
8. Then retract the special tool into the supporting body (1).
9. Tighten the screws (2) on the supporting body.
10. Reinstall the stripper (4) from the special tool (2) with two screws.
11. Retract the pressure die (5) again and tighten the screw (8).
12. Tighten the hexagon-head screw (6) on the special tool.

### Adjusting the special tool

13. To adjust the wall thickness: unscrew screws (6) and (8).



14. Set the wall thickness using the set screw (9).
15. Adjust the chamfer size via the set screw (7).
16. Tighten screws (6) and (8) again after making the adjustment.

#### Tip

In order for the machine to run better: insert the roller holders for tube processing.

## Conversion kits for large material thicknesses

### CAUTION

#### Possible damage to property as a result of defective cap screws

**Spacers with longer cap screws are used for greater material thicknesses. These screws are subject to great stress.**

- When changing spacers, check the cap screws (49) for wear, and replace with new screws if necessary.

For maximum material thicknesses, use a spacer and a longer cap screw.

Spacer and cap screw	Material thickness range
M16x90-12.9 DIN 912 (order number 0023203)	40-80mm
M16x130-12.9 DIN 912 (order number 0023204)	80-120 mm
M16x170-12.9 DIN 912 (order number 0027799)	120-160 mm

Tab. 8

Converting the machine for  
material thicknesses > 40  
mm



Spacer with cap screw

Fig. 54264

1. Loosen cap screw.
2. Remove the block with spindle.
3. Attach the corresponding spacer with spindle.
4. Tighten the cap screw with a moment of 250 Nm.

**Tip**

In order for the machine to run better: insert the roller holders for tube processing.

## Suspension bracket



Suspension bracket

Fig. 54644

- In order to install the suspension bracket on the handle base: screw in the clamping screw (1) in the recess.

## Workstation

The workstation in which the TKF 1500 beveler can be fastened is used for machining small workpieces.

The workstation can be mounted on a base plate or on a pedestal.

The pedestal must be fastened into the floor using a mounting hole.



Workstation with pedestal

Fig. 54645

### Mounting the machine at a workstation

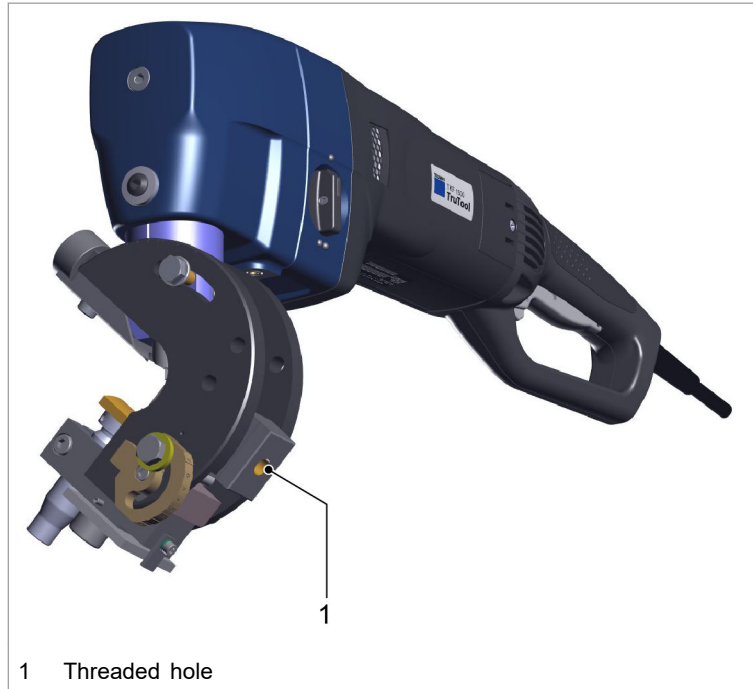

Fig. 84873

- Fasten the machine to the work station using the screw in the threaded hole (1).

## 4. Operation

### 4.1 Working with TruTool TKF 1500 (3A1), (3B1)

**CAUTION**

Damage to property due to turning the gear switch during operation.

Damage to the gearbox can be a consequence.

- Use the gear switch only when the motor is running down or at rest.

Switching the machine on and working

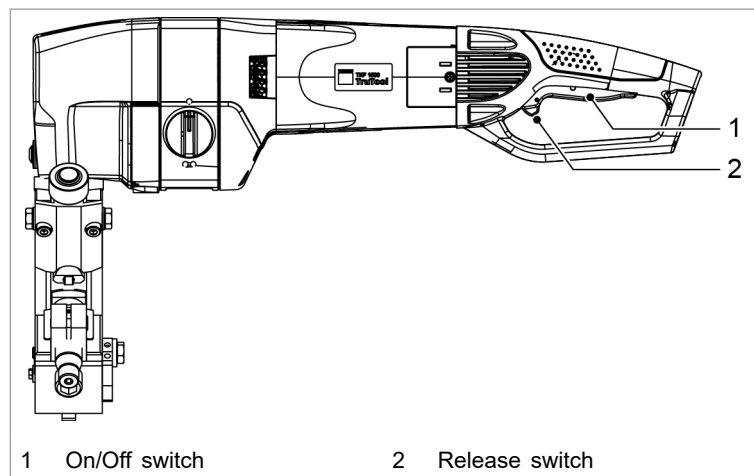

Fig. 84872

1. Performing setting work .
2. For TruTool TKF 1500 (3B1): select gear.
3. Press the release switch (2) forward and hold it.

Press the On/Off switch (1).

The motor is running.

#### Notes

- Do not move the machine towards the workpiece until full speed has been reached.
  - In order to improve the cutting result and increase the service life of the cutting tool, coat the cutting track with oil before machining the workpiece.
4. Processing the material:
    - Place machine on the sheet and at first maintain a few centimetres clearance between the cutting tool and the sheet edge.
    - Push the machine carefully as far as possible against the sheet edge i. e. "piercing".

- 
- Slide the machine along the sheet in such away that the machine axis is roughly parallel to the sheet edge.
  - Press the machine against the sheet edge while doing so.

**Switching off the machine** 5. Press the On/Off switch (1).

## 5. Maintenance

### WARNING

#### Risk of injury due to incorrect repair work

##### Machine does not work properly.

- Maintenance may be carried out by trained specialist technicians only.
- Only use original TRUMPF accessories.

### CAUTION

#### Damage to property caused by blunt tools!

##### Machine overload.

- Check the cutting edge of the cutting tool every hour for wear or in the event of poor cutting behavior or poor work result. Sharp cutting tool produces good cutting performance and protects the machine.
- Change the cutting tool in a timely manner.

Maintenance point	Procedure and interval	Recommended lubricants	Order No.
Sliding sleeve and cutting tool	Lubricate after tool change.	Lubricating grease "S1"	0121486
Gearbox and gear head	After 300 operating hours, arrange for a trained specialist to relubricate or to replace the lubricating grease.	Lubricating grease "G1"	0139440
Lower blank holder	Clean as needed.	-	-
Cutting tool	Regrind as required. Change as needed.	-	-
Sliding sleeve	Change as needed (play between bushing and cutting tool > 0.3 mm).	-	-
Ventilation slots	Clean as needed.	-	-
Supporting body	After 60 m cutting, lubricate the supporting body with a stroke from the grease gun.	Lubricating grease "S1"	0121486

Maintenance points and maintenance intervals

Tab. 9

### 5.1 Regrinding cutting tool

The aluminum cutting tools and heavy-duty cutting tools are ground at an angle on the grinding face. Observe the corresponding regrinding diagram (see "Tab. 7", pg. 14).

The cutting tool for mild steel (order number 0088503) and for high-tensile sheets (order number 0089335) has 2 cutting edges.



## Notes

- Maintain the minimum length of the cutting tools (see "Tab. 7", pg. 14).
  - Do not use shorter cutting tools.
  - Dress the cutting edge with an oil stone after regrinding.
- If both cutting edges are blunt, regrind the cutting tool on the grinding face.

## 5.2 Changing the cutting tool

 **DANGER**

---

**Electrical voltage! Risk of fatal injury due to electric shock.**

- Remove the plug from the plug socket before undertaking any maintenance work on the machine.
- 

 **CAUTION**

---

**Damage to property due to improper handling.**

**Collisions could result from setting the machine incorrectly.**

- Rotate the eccentric shaft one full turn in a clockwise direction using the Allen key provided. If no more collisions occur, remove the Allen key and put the machine into operation in accordance with regulations.
-

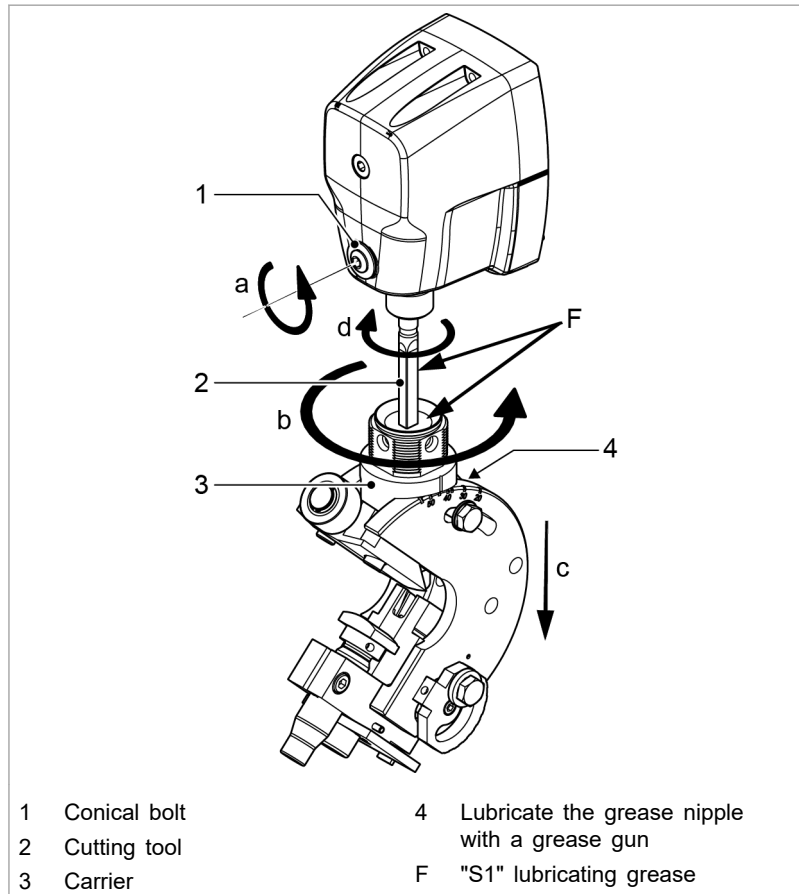
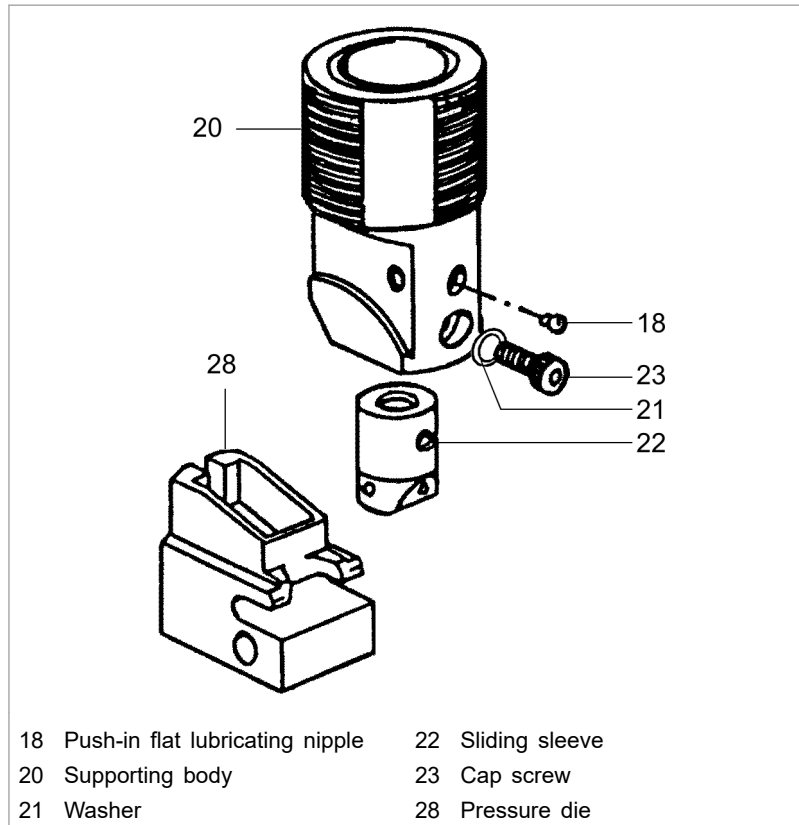

Fig. 85001

1. Release conical bolt (1)
2. Rotate carrier (3) by 45°.
3. Pull carrier out towards the bottom.
4. Screw out the cutting tool (2).
5. Grease the square part of the cutting tool and the bore hole of the carrier slightly with "S1" lubricating grease (order number 0121486).
6. Check the penetration depth of the punch with the setting gauge (order number 1411767).

### 5.3 Change the sliding sleeve

If the clearance between liner and cutting tool is >0.3 mm, then the liner must be changed.



Sliding sleeve

Fig. 9658

1. Release the conical bolt.
2. Rotate supporting body (20) by 45°.
3. Pull the carrier out towards the top.
4. Screw out the cutting tool (2).
5. Undo the cap screw (23), pull the sliding sleeve (22) up and out of the supporting body (20).
6. Slide the new sliding sleeve (22) into the supporting body (20) from above. Observe the orientation.
7. Tighten cap screw (23).
8. Reinstall the supporting body.

## 6. Accessories and consumables

TruTool TKF 1500 (3A1), (3B1)	Order number	Scope of delivery
1x standard cutting tool (TruTool TKF 1500 3A1)	2278672	x
1x high-tensile cutting tool (TruTool TKF 1500 3B1)	2278688	x
1x aluminum cutting tool	2278690	-
1x heavy-duty cutting tool	2278691	-
1x high-tensile cutting tool 5575	2278692	-
2x standard cutting tool	1263021	-
10x standard cutting tool	1263029	-
2x aluminum cutting tool	1264419	-
2x high-tensile cutting tool	1264417	-
10x high-tensile cutting tool	1264418	-
2x high-tensile cutting tool 5575	1327480	-
10x high-tensile cutting tool 5575	1327482	-
2x heavy-duty cutting tool	1264420	-
10x heavy-duty cutting tool	1264432	-
1x sliding sleeve	1884873	x
Punching and nibbling oil for steel (500 ml)	0103387	x
Punching and nibbling oil for aluminum (1000 ml)	0125874	-
Lubricating grease S1 tube 25g	0121486	x
Lubricating grease S1 can 1 kg	0342887	-
Lubricating grease G1 can 900 g	0139440	-
Stripper	0023242	-

Consumables

Tab. 10

TruTool TKF 1500 (3A1), (3B1)	Order number	Scope of delivery
Box for small parts	0353966	x
Operator's manual TKF 1500 (3A1) / (3B1)	2246989	x
Safety information EW	0125699	x
Allen wrench 6mm, l=170x32	0118860	x
Grease gun S1	0068624	x
Screw M10x20	0017302	x
Tube-shaped handle	0023206	x
Chip box	0023209	x
Combination wrench	0078310	x
Handle base	0023229	x
Roller holder compl. right	1238982	x
Roller holder compl. left	1240848	-
Adjusting gauge	1411767	x
Cutting tool selection card	1332341	x
Handle	0023210	-
Spacer compl. (40-80 mm)	0023203	-

TruTool TKF 1500 (3A1), (3B1)	Order number	Scope of delivery
Spacer compl. (80-120 mm)	0023204	-
Spacer compl. (120-160 mm)	0027799	-
Roller holder compl.	0005123	-
Part set compl. (tube processing)	0027798	-
Stripper 55°	0032119	-
Workstation with pedestal	0005079	-
Work station TKF104/TKF1500/-PLUS	0005080	-
Stand lower part	0003677	-
Case	2277078	x

Accessories

Tab. 11

## 6.1 Ordering consumables

### Note

The following data must be specified in order to ensure that parts are delivered correctly and without delay.

1. Specify the order number.
2. Enter further order data:
  - Voltage data
  - Quantity
  - Machine type
3. Specify the complete shipping information:
  - Correct address.
  - Desired delivery type (e.g. air mail, courier, express mail, ordinary freight, parcel post).

### Note

For TRUMPF service addresses, see [www.trumpf-powertools.com](http://www.trumpf-powertools.com).

4. Send the order to the TRUMPF representative office.

---

**7. Appendix: Declaration of conformity,  
guarantee, replacement parts lists**